

FINAL REPORT ON THE ACCIDENT TO THE MISTRAL-C SAILPLANE REGISTERED OO-ZTV IN GOETSENHOVEN ON 23 AUGUST 2009

Ref. AAIU-2009-17
Issue date: 03 SEP 2010
Status: FINAL

FOREWORD.....	III
SYNOPSIS.....	IV
1. FACTUAL INFORMATION.....	5
1.1 HISTORY OF FLIGHT.....	5
1.2 INJURIES PERSONS.....	6
1.3 DAMAGE TO AIRCRAFT.....	7
1.4 OTHER DAMAGE.....	7
1.5 PERSONNEL INFORMATION.....	8
1.6 AIRCRAFT INFORMATION.....	11
1.7 METEOROLOGICAL CONDITIONS.....	14
1.8 AIDS TO NAVIGATION.....	14
1.9 COMMUNICATION.....	14
1.10 AERODROME INFORMATION.....	15
1.11 FLIGHT RECORDERS.....	16
1.12 WRECKAGE AND IMPACT INFORMATION.....	17
1.13 MEDICAL AND PATHOLOGICAL INFORMATION.....	19
1.14 FIRE.....	19
1.15 SURVIVAL ASPECTS.....	20
1.16 TESTS AND RESEARCH.....	20
1.17 ORGANIZATIONAL AND MANAGEMENT INFORMATION.....	20
1.18 ADDITIONAL INFORMATION.....	20
1.19 USEFUL OR EFFECTIVE INVESTIGATION TECHNIQUES.....	20
2. ANALYSIS.....	21
3. CONCLUSIONS.....	23
3.1 FINDINGS.....	23
3.2 CAUSES.....	23
4. SAFETY RECOMMENDATIONS.....	28

AAIU-2009-17

FOREWORD

This report is a technical document that reflects the views of the investigation team on the circumstances that led to the accident,

In accordance with Annex 13 of the Convention on International Civil Aviation, it is not the purpose of aircraft accident investigation to apportion blame or liability. The sole objective of the investigation and the Final Report is the determination of the causes, and define recommendations in order to prevent future accidents and incidents.

In particular, Article 13 of the King's Decree of 9 December 1998 stipulates that the safety recommendations made in this report do not constitute any suspicion of guilt or responsibility in the accident.

Unless otherwise indicated, recommendations in this report are addressed to the Regulatory Authorities of the State having responsibility for the matters with which the recommendation is concerned. It is for those Authorities to decide what action is taken.

The investigation was conducted by L. Blendeman.

The technical investigation of the wreckage was performed by the Aviation Accident Investigation Service (SEAA – ODOV) of the Air Component – Belgian Defense (Report A-01-DGTA-2009).

NOTE:

For the purpose of this report, time will be indicated in UTC, unless otherwise specified.

AAIU-2009-17

Synopsis

Date and hour of the accident

Sunday, 23 August 2009. 12:01 UTC

Aircraft

Eicheldoerfer Flugzeugbau Mistral C, registered OO-ZTV

Accident location

On EBTN (Goetsenhoven) airfield

Aircraft owner

Koninklijke Vliegclub "De Wouw" V.Z.W.

Type of flight

Private

Persons on board

Injuries	Pilot	Passenger	Others	Total
Fatal	0	0	0	0
Serious	1	0	0	1
Minor	0	0	0	0
None	0	0	0	0
Total	1	0	0	1

Abstract

The sailplane was towed by the airplane of the aeroclub "De Wouw". The towing occurred normally on runway 17.

Witnesses saw the sailplane leaving the ground when reaching the lift-off speed.

When the two aircraft were airborne, the sailplane was seen in porpoising – going up and down -. The movement led the sailplane to touch down the pavement two or three times.

Finally, the sailplane went airborne again, but turned to the right. The tow cable got detached, and the sailplane was seen in a roll, and crashed on its back at the RH side of the runway.

The sailplane pilot climbed out, and was brought to the hospital. He suffered from multiple injuries and head fracture.

AAIU-2009-17

1. Factual information.

1.1 History of flight.

The pilot is a member of the aeroclub “De Wouw”, and wanted to perform a flight with a sailplane belonging to the aeroclub.

The weather was adequate, and there were already 12 flights performed that afternoon with various sailplanes and pilots.

The sailplane was towed by the airplane of the aeroclub “De Wouw”. The towing occurred normally on runway 17.

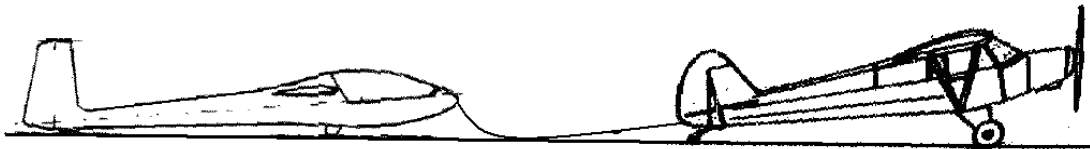

Witnesses saw the sailplane leaving the ground when reaching the lift-off speed.

When the two aircraft were airborne, the sailplane was seen porpoising – a pitching oscillation; the sailplane going up and down – two or three times.

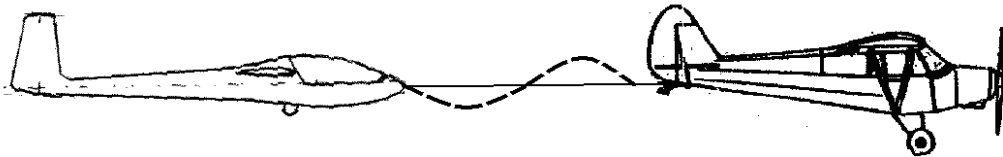

The last downward movement led the sailplane to hit the runway pavement.

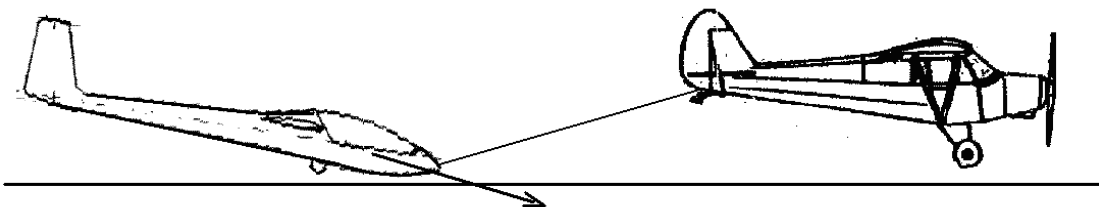

Note: the tow cable is 40m long and is not represented to scale.

AAIU-2009-17

The tow cable got detached. The sailplane climbed, turning to the right in a roll movement, going down. The sailplane went inverted, and crashed on its back at the RH side of the runway 24. The height reached by the sailplane is stated by several witnesses to be 50m, although this seems quite high, and is more believed to have been between 10 - 15 m.

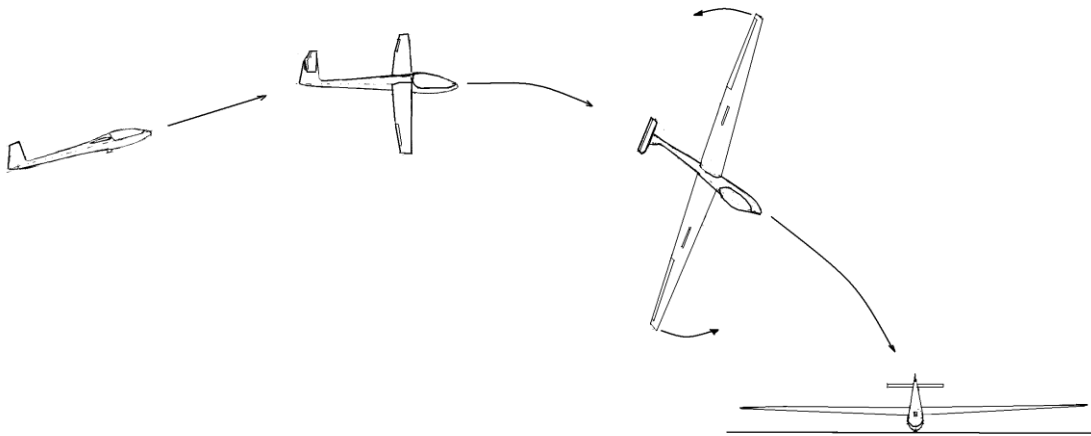

The sailplane pilot climbed out, and was brought to the hospital. He suffered from multiple injuries and head fracture.

1.2 Injuries to persons.

Injuries	Pilot	Passenger	Others	Total
Fatal	0	0	0	0
Serious	1	0	0	1
Minor	0	0	0	0
None	0	0	0	0
Total	1	0	0	1

AAIU-2009-17

1.3 Damage to aircraft.

The damage on the sailplane was assessed by a team from the Aviation Accident Investigation Service (SEAA – ODOV) of the Air Component – Belgian Defense. (Report A-01-DGTA-2009).

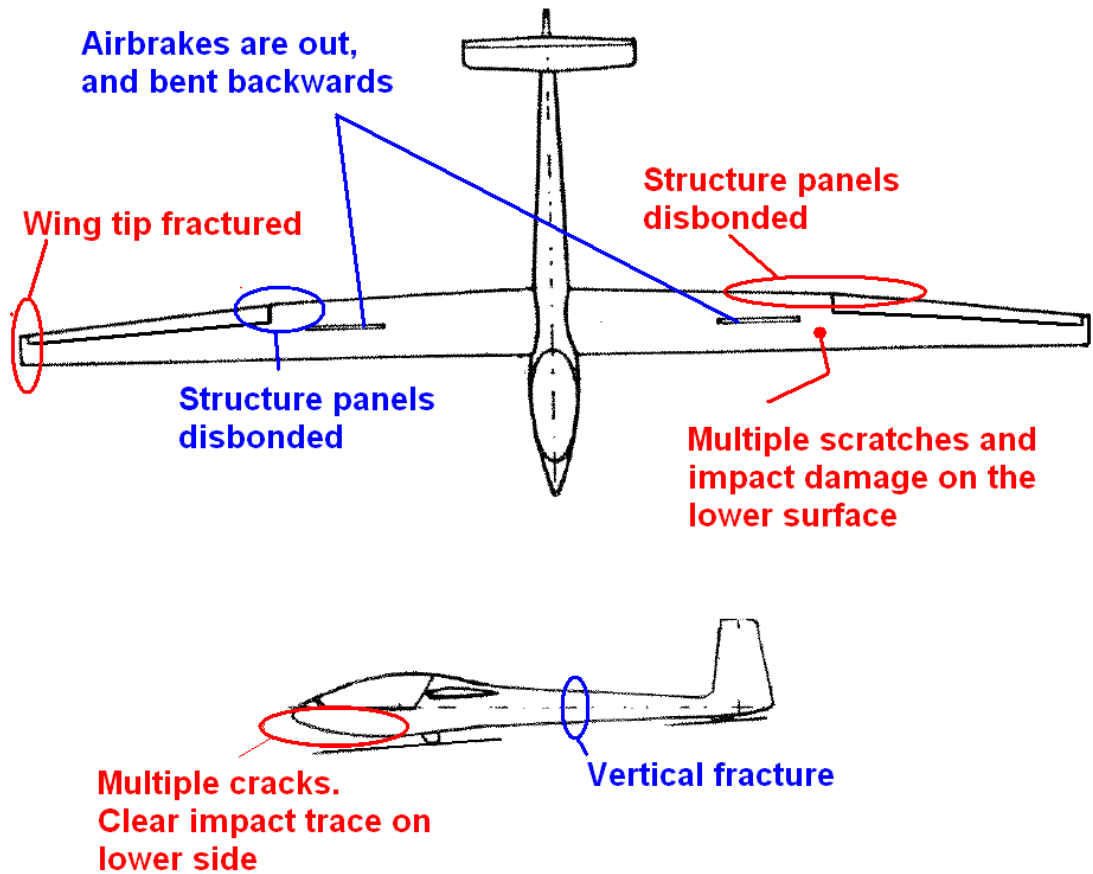

Damage description

1.4 Other damage.

None.

AAIU-2009-17

1.5 Personnel information.

Sex: male
Age: 45 years old
Nationality: Belgian
License: Glider Pilot License issued on 29 April 2009 by the Royal Belgian Aeroclub.
Authorization to carry passengers 15 August 2009.
Holder of D1 brevet; (1000m) on 30 May 2009.
Medical: Valid until 6 April 2011.

The pilot, after the crash did not have any recollection of the circumstances of the crash.

Flight Experience

Total: 81:29 FH / 179 Flights
Total DC: 27:04 FH / 100 Flights
Total Solo: 54:25 FH / 79 Flights

First flight: on 14 November 2004
First solo flight: 6 May 2007
First flight on Composite airplane (SF34): 4 May 2008
First solo flight on Composite airplane: 26 July 2009
Flight on Mistral: 26 July 2009

Flights for the last 15 days:
1 flight of 5:25 FH in K8
2 Flights with passengers (evaluation flights) on SF34.
1 Flight on Ka6: 11 min.

Flights for the last 6 months: 24:52 FH,
including 10 Flights /11FH on SF34

Most of the experience in solo flights is done on Ka6 / K8 sailplanes.

AAIU-2009-17

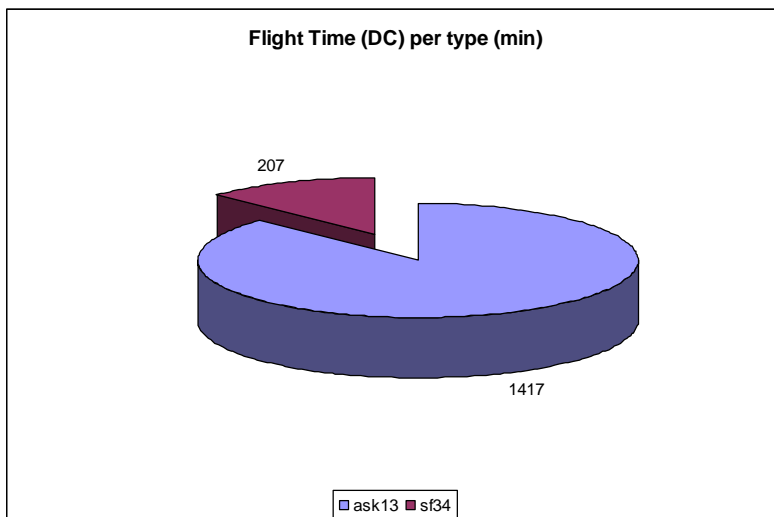
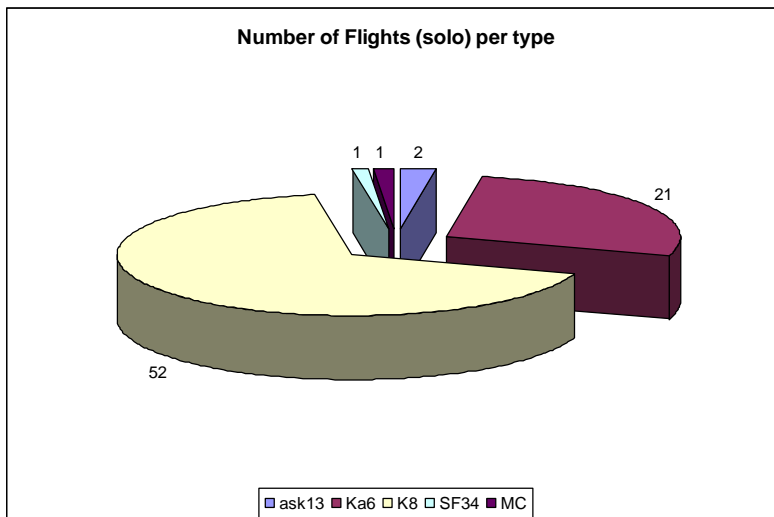
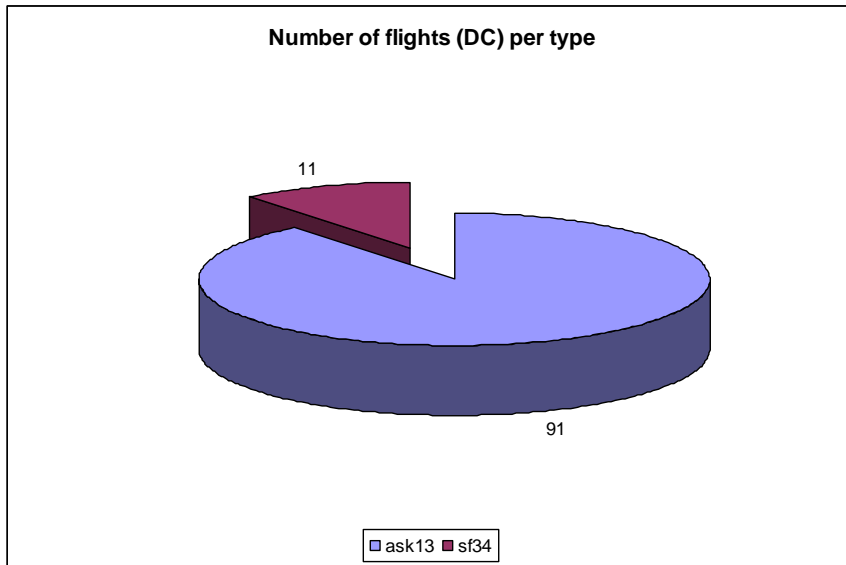

AAIU-2009-17

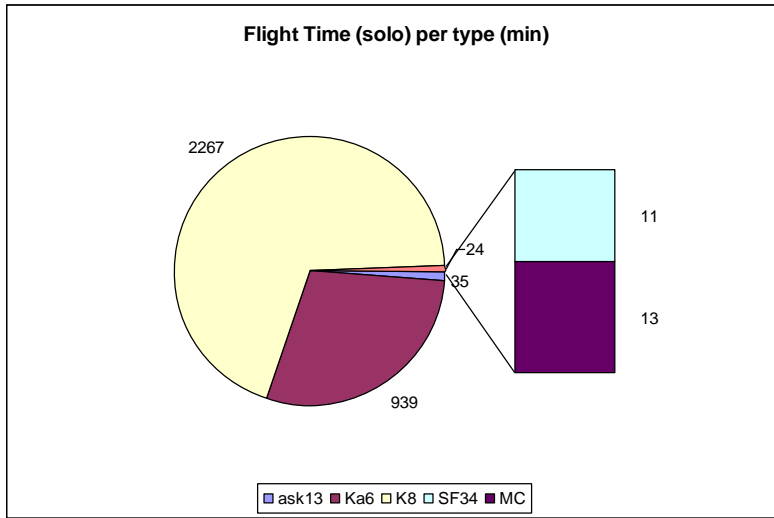

AAIU-2009-17

1.6 Aircraft information.

The Mistral-C Sailplane

The Mistral-C is a high performance Standard Class Sailplane, with a cantilever shoulder-wing monoplane, with air brakes on the upper surface.

The sailplane type was certified by the German Luftfahrt-Bundesamt, under the reference Segelflugzeug-Kennblatt Nr 329, issue 5 dated 03 Jul 1998.

The fuselage is a pod and boom monocoque with a fiberglass/wood sandwich structure.

Wingspan: 15m
Length: 6.67m
Height over tail: 1.33m
Best Glide ratio: 39 (95km/h)
Min sink speed: 0.63 (85km/h)
Weight: 220 kg
Max weight: 350 kg
VNE: 250 km/h

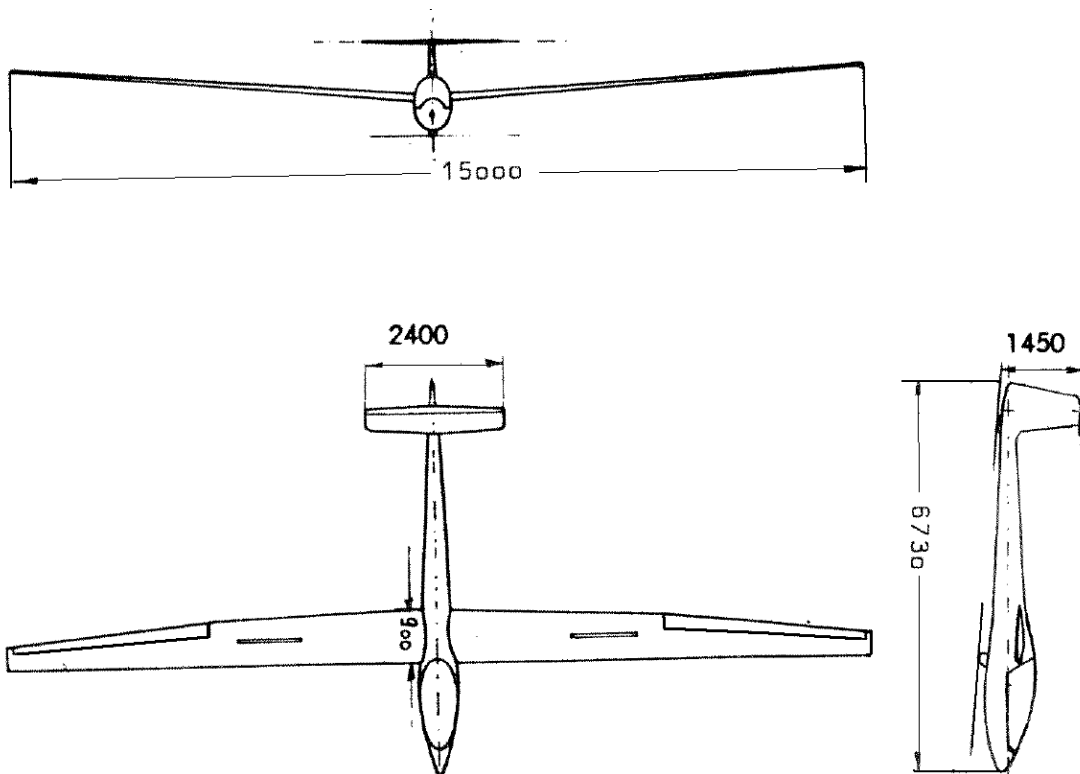

AAIU-2009-17

Airframe:

- Manufacturer: Eicheldoerfer Flugzeugbau (Valentin)
- Type: Mistral C
- Serial number: MC 059/85
- Built year: 1985
- Registration: OO-ZTV
- Certificate of registration: Nr 3473, last issued on July 19, 2004
- Certificate of airworthiness: Last issued on April 11, 2008
- Airworthiness inspection: 9 April 2009.

Total Flight Hours: 1407:41 FH

The sailplane was equipped with a Nose Tow release,

- Make: Tost GmbH
- Model: E75
- Serial: 23571
- Overhauled: 03 Dec 1998
- Accumulated releases: 618 (at the time of the accident)

The tow release must be activated by the pilot using a handle in the cockpit. A weak link is installed in the tow cable to allow liberating the cable in case of overstress. This weak link was found intact.

The LBA-issued Airworthiness Directive LTA 89-18/3 is applicable, and requires an overhaul of the towing mechanism every 2000 releases.

Owner: Koninklijke vliegclub "De Wouw"

AAIU-2009-17

The towing airplane

The towing airplane is a Piper PA-18 equipped with a towing hook.

Airframe
Manufacturer: Piper Aircraft Corporation
Type: Piper PA-18-150
Serial Number: 18-8286
Built year: 1965
Registration: OO-VVC
Certificate of Registration: 1597
Certificate of Airworthiness: (ICAO) Last issued on 19 December 2008,
valid until 18 December 2009.

Engine
Manufacturer: Lycoming
Type: O-320-A2B

Propeller
Manufacturer: Hoffman
Type: HO 23B-HM 195 B112

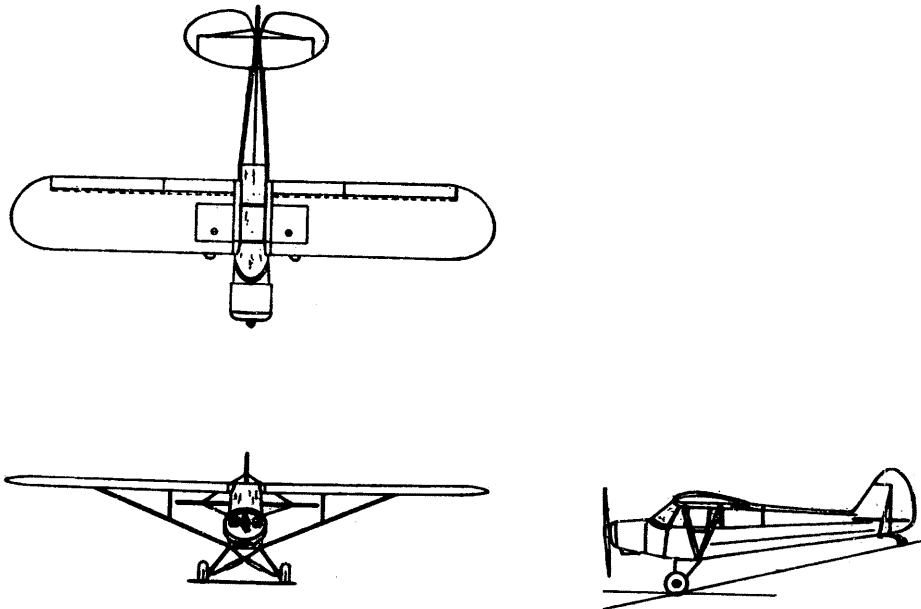

AAIU-2009-17

The airplane is approved for training flights and the towing of banners and sailplanes.

Maintenance.

The aircraft was maintained in accordance with the maintenance programme / Inspection Report ref. 230-202, rev 22/08/99.

Towing

The airplane is equipped with a Tow release,

- Make: Tost GmbH
- Model: E75
- Serial: 20222
- Overhauled: 22 Oct 2008
- Installed: 20 Apr 2009
- Accumulated releases: 870 (on 13 Nov 2009)

The LBA-issued Airworthiness Directive LTA 89-18/3 is applicable, and requires an overhaul of the towing mechanism every 2000 releases.

Owner: Koninklijke vliegclub "De Wouw"

1.7 Meteorological conditions.

Wind.

Direction: 180°

Speed: 9 kts

Atmospheric pressure (QNH): 1021 hPa

Temperature: 28°C

Clouds

A few Cumulus at 4500 ft

Visibility: more than 10 km

1.8 Aids to navigation.

None

1.9 Communication.

The sailplane is equipped with a radio (FSG 40S) – the frequency was set to 125.325. (Goetsenhoven radio is 123.375).

However, communications are not recorded and the communication between sailplane and towing airplane are usually done visually.

AAIU-2009-17

1.10 Aerodrome information.

The Goetsenhoven airfield (ICAO: EBTN) is a Military Airfield of the Belgian Air Component, located 2 miles (3.2 km) south of Tienen and approximately 26 miles (42 km) east-southeast of Brussels.

The airfield is also used on week-ends by the local flying club De Wouw

Coordinates: 50°46'54"N - 004°57'28"E
Elevation: 246 ft

Runway 06/24:
QFU: 060°/240°
Dimension: 655 m x 30 m
Surface: Asphalt
Strength: LCN 20

Runway 17/35:
QFU: 170°/350°
Dimension: 779m x 30m
Surface: Asphalt
Strength: LCN 20

Opening Hours (Civilian Use)
Saturday, Sunday and Holidays: 07.00 till Sunset

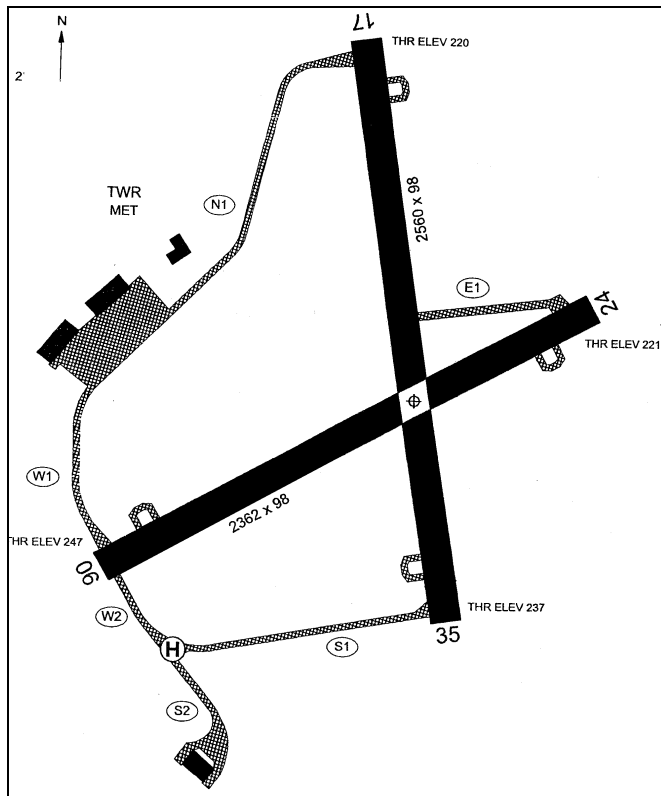

AAIU-2009-17

1.11 Flight recorders.

The sailplane is equipped with a Flight Logger LX20-2000 (sn 20221).

The logger records the GPS position and time, and computes flight data, among others;

- Position,
- Ground speed,
- Altitude,
- Heading
- Rate of climb,

Time	Altitude	Grd Speed	Rate of climb	Heading
	(m)	(km/h)	(m/s)	(degrees)
12:10:29	44	9	0	162
12:10:41	45	54	0,6	171
12:10:45	48	68	0,7	168
12:10:48	50	89	0,6	168
12:10:50	51	102	0,8	168
12:10:52	53	101	1	180
12:10:54	55	101	1	192
12:10:58	57	51	-0,8	192
12:11:02	51	27	-1,3	232
12:11:06	49	27	0	232

The data were read using the SeeYou software v3.95 of Naviter.

AAIU-2009-17

1.12 Wreckage and impact information.

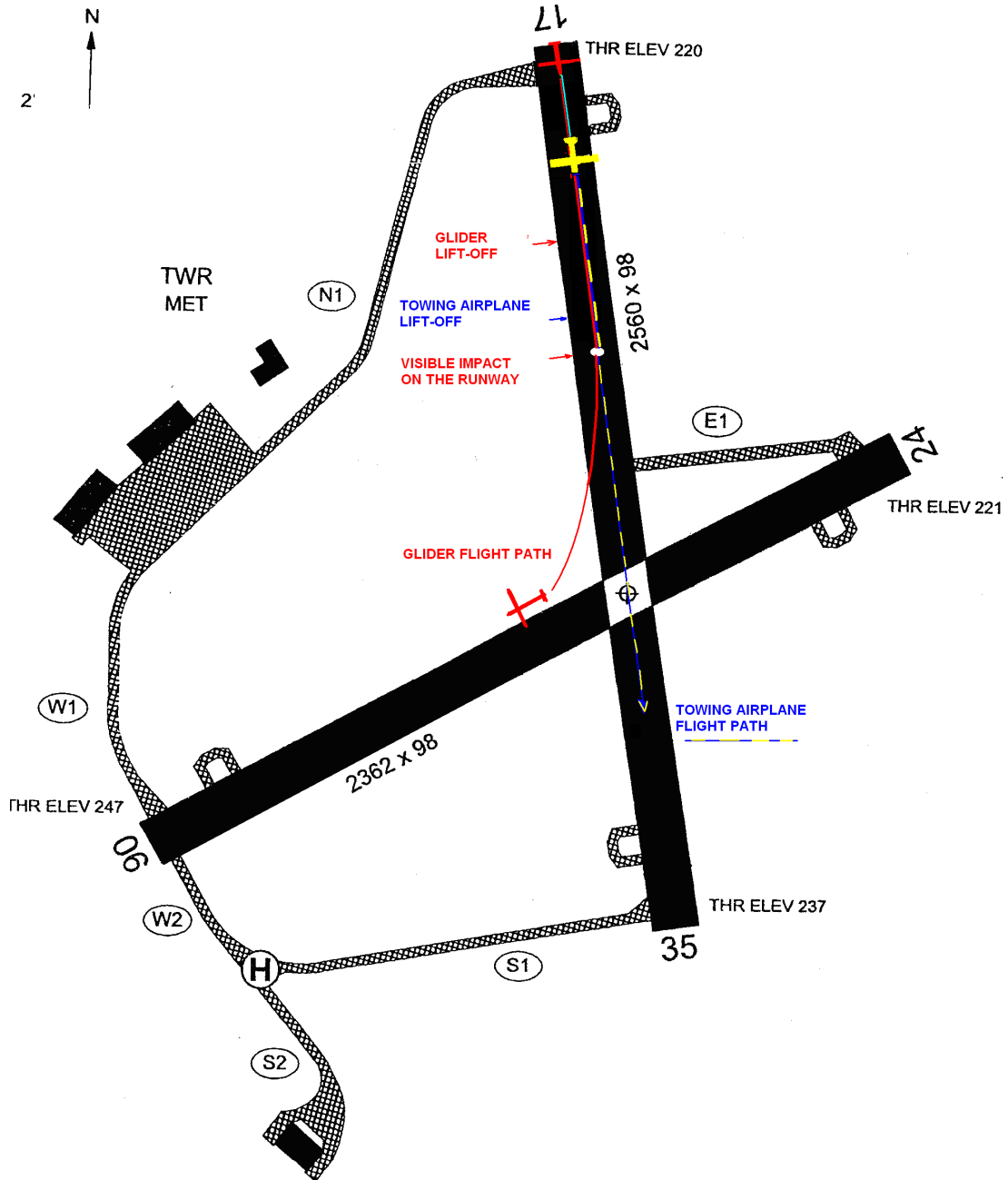

AAIU-2009-17

The sailplane impacted the runway two or three times; the last impact was quite violent, and left a white mark on the runway. During this impact, the wing bent downwards and impacted the runway surface.



The first impact was located below the nose of the sailplane, under the cockpit.

A second shock occurred when the sailplane impacted the ground, inverted. It slipped on the grass for several meters before the final stop.



AAIU-2009-17



1.13 Medical and pathological information.

The pilot suffered head injuries, commotion

1.14 Fire.

There was no fire.

AAIU-2009-17

1.15 Survival aspects.

The pilot was seated correctly, with seat belts and straps on.

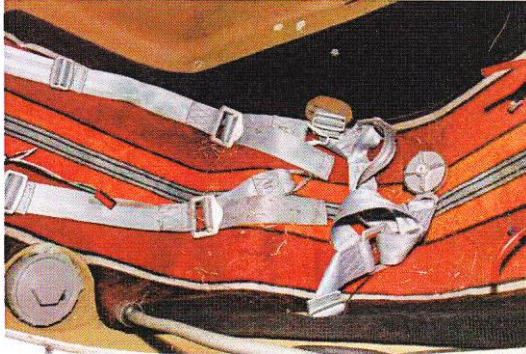

The vertical shock on the canopy was only limited by the glass canopy. The pilot had no head protection, nor was he supposed to wear one.

1.16 Tests and research.

None.

1.17 Organizational and management information.

Not applicable.

1.18 Additional information.

Not Applicable

1.19 Useful or effective investigation techniques.

Not Applicable

AAIU-2009-17

2. Analysis.

2.1. Technical inspection.

Mistral-C sailplane OO-ZTV

The report on the damage to the sailplane, (A-01-DGTA-2009) concluded that all damage found on the sailplane were due to the violent impact with the ground.

There is no indication of any technical anomaly prior to the accident.

The tow release was tested after the accident, and was found to operate normally.

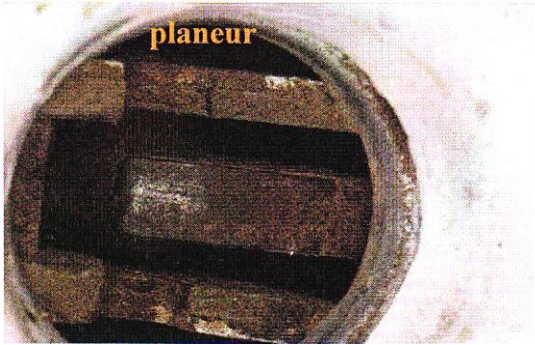

The sailplane was airworthy before the flight.

Piper PA-18 towing airplane OO-VVC

The inspection on the airplane revealed no anomalies related to the accident.

The tow release was tested after the accident, and was found to operate normally.

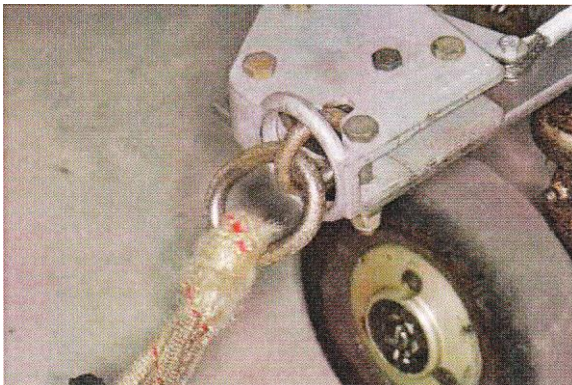

AAIU-2009-17

2.2. Meteo

The meteorological conditions were favourable for sailplane flying. With respect to take-off, the wind direction (180°) is nearly corresponding to the runway axis (170°).

In the afternoon, there were strong thermal conditions (28°C), that would have warmed up the dark runway inducing turbulent air over the runway.

2.3. The Sailplane pilot

The qualification of the pilot is quite adequate and 'standard' with respect to a normal training pattern.

The initial training was performed on a Schleicher ASK13 two-seater and the subsequent experience was gained on single-seaters Ka6 and K8.

These three types of sailplanes are from the wood and fabric construction, opposed to the modern composite structure, such as the Mistral-C.

The pilot had started a familiarisation with the composite-structure sailplanes, flying with the two-seater Scheibe SF34 Delphin of composite construction.

The pilot achieved a first solo flight on SF34 on 26 July 2009, followed by a flight on the Mistral-C on the same day.

The pilot flew only 4 times after that, including two flights on SF34.

There are notable differences in handling between the "wood and fabric" and "plastic" sailplanes, from the pilot point of view; one being the operating speeds (10...15 % higher for composite)

Speed (km/h)	ASK13	K8	Ka6	Mistral-C
VNE	200	190	200	250
Max speed by aerotow	140	130	140	160
Stall Speed	53-59	52	62	72

and, as reported by sailplane instructors, a higher sensitivity of the response on the elevator for the Mistral-C compared to the other types (K8 – Ka6).

AAIU-2009-17

2.4. The Flight

a. Lift-off

Initially, the take-off of the sailplanes and the towing airplane occurs normally, according to witnesses. The sailplane increases speed up to the point where the pilot decides to leave the ground.

The flight logger indicates a gradual speed increase up to 100 km/h, which is normal and adequate for a take-off.

b. Leaving the ground

The sailplane is then seen porpoising; oscillating in altitude, also referred to as 'dolphin movement'. Witnesses report two to three oscillations, from which at least the last one leads the sailplane to hit the runway with violence. This last event occurs when both aircraft are flying.

The shock is felt by the pilot of the towing airplane as a deceleration, more or less in the flight axis. The trace on the runway is indeed in the axis of the runway.

At that time (the towing airplane is airborne), the speed of the sailplane is above its stall speed. The sailplane is still attached to the towing airplane.

The porpoising of the sailplane during take-off can be influenced by the following 3 effects:

- Thermal activity
- Ground effect,
- Wind velocity gradient
- Pilot input.

Thermal activity.

As introduced in paragraph 2.2. on meteorological conditions, the thermal conditions of the time of the day were particularly high.

This is quite favourable for flying, as thermals will hold sailplanes in the air for a much longer period, but will induce turbulences on take-off.

The sun will heat the dark runway, and the air above the runway will move upward. This movement will influence the lift on the wing.

These air turbulences will be felt by the pilot, who will try to compensate their effect to keep the sailplane in a straight line of flight.

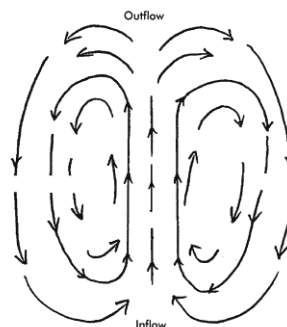

AAIU-2009-17

Ground effect.

The ground effect, is related to an increase in air pressure which occurs below a wing of an airplane when it comes into close proximity with the ground.

The ground effect creates an additional lift effect when a wing is flying close to the ground.

Sailplanes are less affected by ground effect than powered airplanes due to the specific shape of the wing; the short chord and very long wingspan (in other words, high aspect ratio).

At take-off, the ground effect is helping the wing to lift-off. However, once the wing climbs to a height at which the ground effect disappears, the lift will decrease.

Wind velocity gradient

The wind velocity gradient is the vertical gradient of the mean horizontal wind velocity close to the ground. Close to the ground, the airstream is forced to slow down by friction with the surface.

In this case the wind direction was nearly in the opposite direction of the flight (difference of 10°); the wind velocity outside the ground friction effect was 9 knots – 17 km/h. At 0.5..1 m above ground, this velocity is lower.

This wind velocity will add on the ground speed to become the airspeed i.e. the speed “felt” by the wing, creating the lift.

During towing, for a wing flying close to the ground, as during take-off, the wind velocity will increase, and therefore the lift, when the wing is moving up. The pilot of the sailplane must then adjust his controls to maintain the altitude of the sailplane behind the towing airplane.

Sailplane pilot input.

During take-off, the sailplane pilot must maintain the sailplane in a straight flight on the same level as the towing airplane, by acting on the flight controls. He may therefore react to the effects seen here above, by pushing or pulling the stick, causing the airplane to move up or down.

A known phenomenon is the over-reaction of the sailplane pilot to external effects, or reaction with a slight delay, causing the general movement of the airplane to increase, instead of stopping.

Although having the sailplane general behaviour appropriately under control, a pilot not thoroughly familiar with the response of the sailplane to his inputs may have a tendency to apply corrections to the flight controls too early or too late. This would cause the sailplane to deviate from the intended flight path.

AAIU-2009-17

This over-reaction is a reflex action of the pilot that can only be corrected in time by acquiring experience on the type of sailplane, as each type of sailplane is different, and reacts differently on the external factors.

In this case, the low experience of the sailplane pilot on the new type of sailplane would have had a negative influence.

c. Sailplane release

After the last contact with the runway, causing a severe shock, the sailplane is released from the towing airplane. This release was done from the sailplane, by the sailplane pilot (as the weak link was found intact).

As seen above, the pilot of the towing airplane felt a shock in the flight axis, and did not feel any yaw movement afterwards. When the towing pilot looked in the rearview mirror, he saw the sailplane in a (normal) turn to the right.

This turn might be the result of either the conscious action of the pilot on the flight controls, or a natural movement of the sailplane due to the damage consecutive to the shock.

Pilot action.

A turn to the right after the release would not be the obvious course of action after the collision with the runway.

After release, it would be more appropriate to fly straight and land on the same runway.

Also, the turn to the right might have been induced by the roll. The roll was not stopped, and resulted in the sailplane to go inverted.

It is quite unlikely that the pilot would have consciously chosen that solution.

AAIU-2009-17

Influence of the damage.

The damage during the collision with the runway was quite violent, causing the wing to bend and hit the runway surface. This would have caused a forced deformation of the wing, in turn causing structural damage, as earlier explained

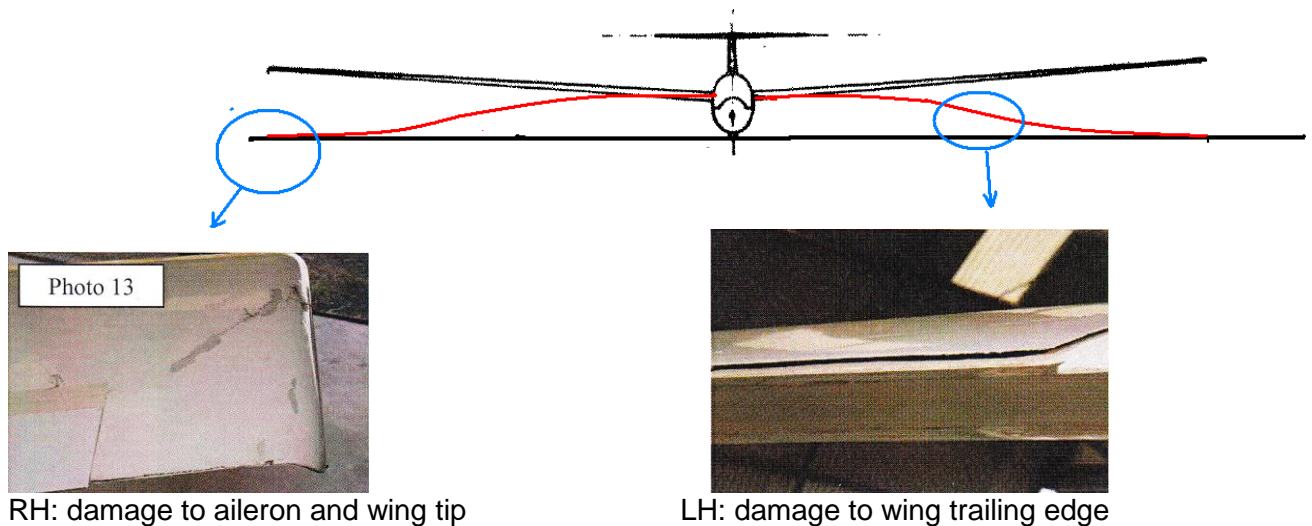

In particular, the RH Wing tip was damaged, while the LH Wing tip did not show damage, indicating the shock was heavier on the RH side than on the LH side.

The wing skin de-bonded at the trailing edge, on both RH and LH wing.

The ailerons were also damaged (but probably during the second blow).

The findings were made after the second impact (inverted in grass), that would also have caused damages, but the damage seen on the RH wing tip and on the lower surface were without doubt done during the first impact.

These damage are susceptible to influence the wing performance, and could possibly lead to (RH wing more damaged) cause the sailplane to turn right, without input from the pilot. The actual influence of the damage to the flight path could not be simulated nor reproduced with absolute certainty.

All the flight controls were connected and functional after the crash, but we could not determine whether their effect could have been counteracted by action of the pilot (due to temporary blockage of the aileron, loss of efficiency of the aileron,)

AAIU-2009-17

d. Roll and crash.

As we have seen above, the sailplane went into a roll to the right, but the roll was not interrupted, and the sailplane went inverted, and crashed – nose first – on the grass on the RH side of runway 24.

3. Conclusions.

3.1 Findings.

- The sailplane pilot was duly qualified.
- It was the second flight of the pilot on a Mistral-C, and most of his experience was on different technology sailplanes (wood and fabric as opposed to composite structure).
- The sailplane was airworthy.
- The towing airplane was airworthy.
- The towing mechanism was found operational after the incident.

3.2 Causes.

The accident was caused by the porpoising movement of the sailplane upon take-off, leading to a heavy collision with the runway, and resulting in a loss of control.

Known contributing factors include the low experience of the pilot on sailplanes of composite structure and the strong thermal activity of the time of the day.

AAIU-2009-17

4. Safety recommendations.

4.1. Recommendation 2010-S-1.

AAIU(be) recommends the Belgian Federations of Sailplanes to issue a recommendation to the clubs and instructors.

Glider pilots, converting to new types of sailplane that are known to have more sensitive response to the controls than the types flown before, should be advised:

- to have received an appropriate briefing on the new type of sailplane,
- to make the first flights in calm weather conditions (in the morning or late afternoon/evening under supervision of an instructor,
- to gain sufficient experience avoiding strong thermal activity conditions,
- to make a check flight with an instructor after some solo flights using a two-seater having similar characteristics (when available).